

Technical
Drawing

Desenho
Técnico

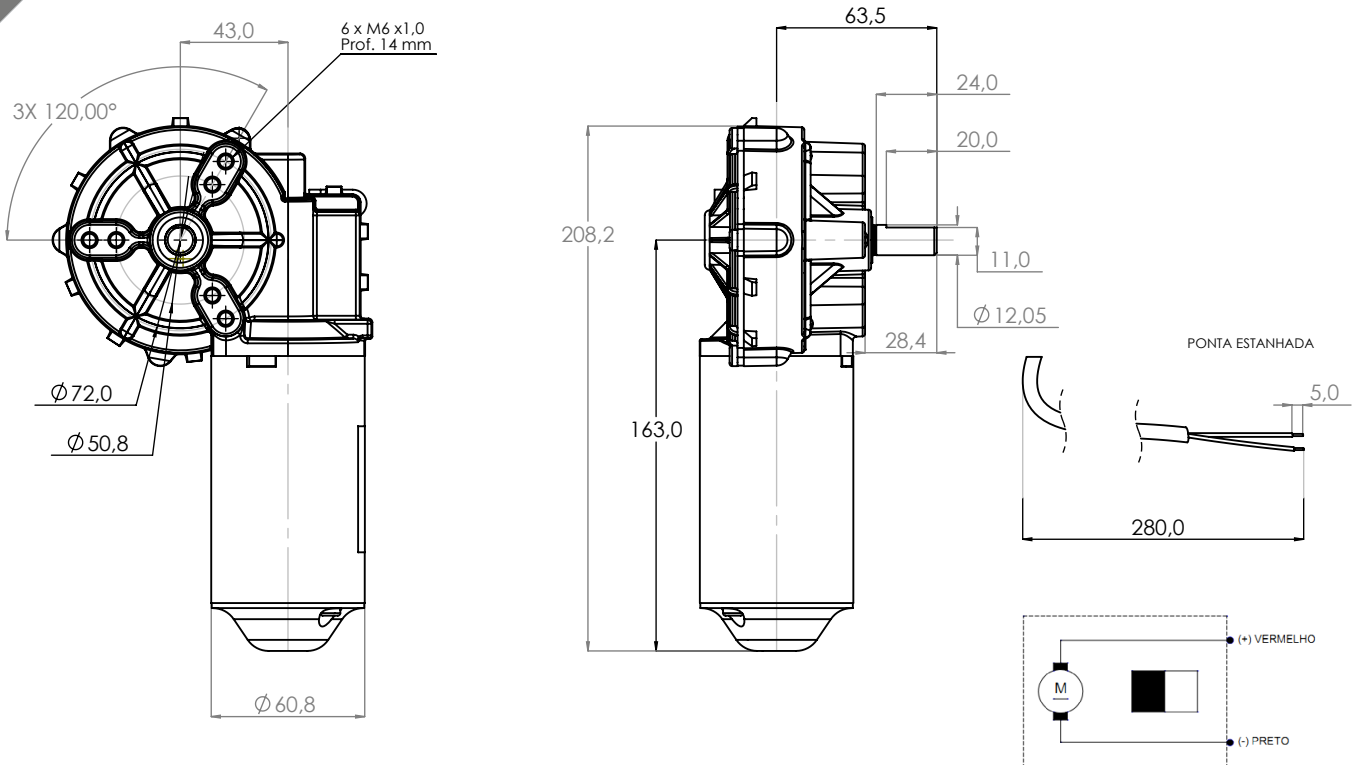

Technical
Specification

Especificação
Técnica

Imagem
Ilustrativa

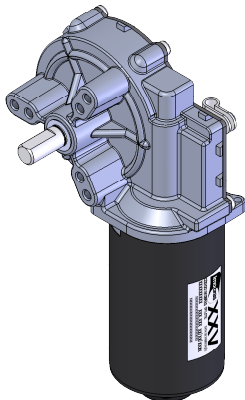

100502112

CARACTERÍSTICAS ELÉTRICAS	
U _N (V)	13
P _N (W)	25
n _N (rpm)	29
I _N (A)	5,5
I _{max} (A)	23
M _N (Nm)	8
M _{max} (Nm)	49
I	55:1
Rotação	L / R
Peso (Kg)	1,700

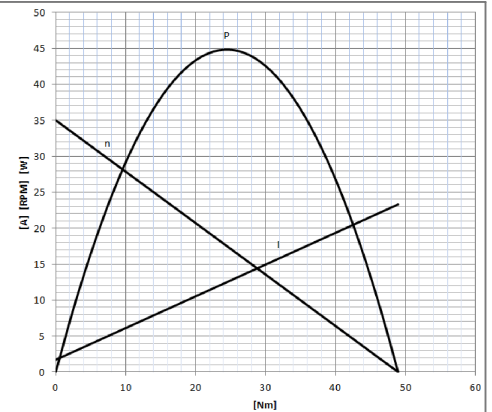

100502124

CARACTERÍSTICAS ELÉTRICAS	
U _N (V)	27
P _N (W)	28
n _N (rpm)	30
I _N (A)	2,7
I _{max} (A)	10,5
M _N (Nm)	8
M _{max} (Nm)	50
I	55:1
Rotação	L / R
Peso (Kg)	1,700

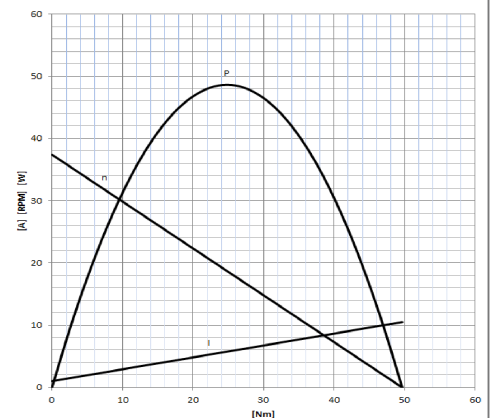

NOTAS:
Aplicação: Industrial

NOTES:
Application: Industrial